

TSW-570

5 in. Wall Mount Touch Screen



- Next generation Crestron® wall mount touch screen
- 5 in. (127 mm) widescreen active-matrix color display and 1280 x 720 HD 720 display resolution
- Capacitive touch screen display
- Custom-programmable virtual control buttons
- Supports Crestron HTML5 and Smart Graphics® software custom user projects
- H.265, H.264, or MJPEG streaming video display
- Native Crestron room scheduling app
- Built-in web browsing
- Single wire Ethernet connection with PoE or PoE+ power
- Dual USB 2.0 ports for room availability accessories
- Enterprise grade security and authentication
- Web, cloud, or device-based configuration
- Wall mounting with provided mounting bracket

The Crestron® TSW-570 is a stylish and versatile wall mount touch screen that is ideal for residential and enterprise applications. The TSW-570 features a 5 in. (127 mm) capacitive touch screen display with custom-programmable control buttons and support for Smart Graphics® software and HTML5-based custom UI projects. PoE connectivity and a comprehensive assortment of mounting accessories simplify new and retrofit installations.

Advanced Touch Screen Control

The TSW-570 offers a sleek and powerful user interface for controlling technology in a home, boardroom, classroom, or command center. The touch screen provides an intuitive interface that is fully customizable with easy-to-use capacitive controls, true feedback, and real-time status display. A built-in proximity sensor wakes the screen without requiring any user interaction, and automatic brightness controls ensure optimal visibility under varying lighting conditions.

Custom-Programmable Virtual Buttons

The TSW-570 provides a universal status bar that is populated with virtual buttons for quick access to common touch screen functions. The touch screen comes preconfigured with virtual buttons for Power, Home, Lights, Up, and Down. Each button can be programmed via a Crestron control system to provide custom functionality, and unused buttons can be hidden individually. The universal status bar is expanded or hidden using simple swipe gestures on touch screen display.

Dynamic User Interfaces

The TSW-570 supports custom user interfaces created with [Crestron HTML5 User Interface](#) and Smart Graphics technologies, allowing greater flexibility for UI developers and programmers.

- Crestron HTML5 User Interface enables UI designers to develop rich, front-end user interfaces with increased reusability and efficiency using modern web methodologies. Crestron HTML5 User Interface development tools are provided to simplify creating user interfaces built on standard web technologies
- Smart Graphics enables programmers to integrate fluid gesture-driven controls, animated feedback, rich metadata, embedded apps and widgets, and full-motion video into their user interfaces. Smart Graphics provides dynamic features such as graphical buttons and sliders, lists and toolbars, drag-and-drop objects, dashboard widgets, screensavers, and customizable themes.

Streaming Video

Native support for H.265, H.264, and MJPEG formats allows the TSW-570 to display live streaming video from an IP camera, a streaming encoder (Crestron [DM-TXRX-100-STR](#), or similar), or a [DigitalMedia™ switcher](#).¹ Video is delivered to the touch screen over Ethernet, eliminating the need for any extra video wiring.

Crestron Room Scheduling App

As part of a complete enterprise room scheduling solution, the TSW-570 can be deployed as a scheduling panel via the Crestron room scheduling app. A Crestron scheduling panel can be installed at the entrance of a meeting room to provide indication of the room's availability and a view of its schedule for the day. If desired, the room can be reserved on the spot for an ad hoc meeting. A [CEN-ODT-C-POE](#) occupancy sensor can also be paired to the touch screen, allowing for occupancy status to be reported instantly to the scheduling app for no-shows and unscheduled room usage.^{1,2}

Running the Crestron Scheduling App, the TSW-570 integrates directly with [Crestron Fusion®](#) software, Microsoft Exchange Server® software (for users of Outlook® software and Office 365® software), the Google Calendar™ calendaring app (including G Suite™ software), CollegeNET® 25Live® scheduling software, or Ad Astra™ software. IBM® Notes® software is also supported through a Crestron Fusion on-premises server.

TSW-570

5 in. Wall Mount Touch Screen

Crestron Home OS Control

The TSW-570 may be used to control a [Crestron Home™ OS](#) whole home solution. Select the Crestron Home app from the touch screen to control lighting, shades, climate, media, security, and cameras, including the ability to create and recall scenes that create a desired ambiance throughout a home. A TSW-570 may be installed in each room to provide easy access to various Crestron Home functions for both the room and the home.

Web Browsing

Using its built-in web browser, the TSW-570 provides access to online program guides and other web-based services, and it can be used to control DVRs and other devices without having to pick up a separate tablet or smartphone.³

Wired Connectivity

An Ethernet LAN connection is all that is required to wire the TSW-570, containing all control, video, and power signals within a single wire.

Power over Ethernet

Using PoE technology, the TSW-570 gets its operating power directly through the network cable. PoE (Power over Ethernet) eliminates the need for a local power supply or any dedicated power wiring. Crestron PoE switches ([CEN-SW-POE-5](#) or [CEN-SWPOE-16](#)¹) offer a total networking solution with built-in PoE for multiple touch screens. A PoE Injector ([PWE-4803RU](#)¹) is also available to support a single touch screen.

NOTE: Refer to the "Power" specifications for more details.

Room Scheduling Accessories

The TSW-570 provides dual high-speed USB 2.0 ports for connecting supported Crestron room scheduling hallway sign accessories to the touch screen. The [SSW](#), [SSW-EL](#), [SSC](#), and [SSC-EL](#) series hallway signs feature a two sided acrylic sign face that can be custom engraved with the room name or number. The [SIW-100](#) offers a lower profile wall mount status indicator.¹

Enterprise-Grade Security

Crestron touch screens employ enterprise-grade networking with robust security features such as 802.1X authentication, TLS encryption, HTTPS connectivity, and Active Directory® service integration. These features are imperative to protect your network against service interruptions and malicious intrusions, and to ensure compliance with your organization's network policies. Cloud-based provisioning and management streamlines the process of configuring, monitoring, and updating every touch screen on the network. Additional support for SNMP allows the touch screen to be monitored by your IT administrator.

XiO Cloud Service

The TSW-570 is compatible with the XiO Cloud® service, which is an IoT (Internet of Things) based platform for remotely provisioning, monitoring, and managing Crestron devices across an enterprise or an entire client base. Built on the Microsoft® Azure® software platform and utilizing Microsoft's industry-leading Azure IoT Hub technology, XiO Cloud enables installers and IT managers to deploy and manage thousands of devices in the time it previously took to manage just one. Unlike other virtual machine-based cloud solutions, Azure services provide unlimited scalability to suit the ever-growing needs of an enterprise. For more information, visit www.crestron.com/xiocloud.

Wall Mount Options

The TSW-570 is easily installed into drywall and other surfaces using the included [TSW-UMB-70](#) universal mounting bracket, which affords the following mounting options:⁴

- Can be used by itself as a postconstruction solution for retrofitting the TSW-570 into existing drywall.
- Can be used with the included [TSW-UMB-70-PMK](#) preconstruction mounting kit for applications that don't require a back box.
- Can be used with the [TSW-UMB-70-BBI](#) back box for masonry and concrete applications.¹

A security bracket option is also included to deter unauthorized removal of the touch screen.

Optional Mounting Accessories

The [TSW-570/770-RMK-1](#) rack mount kit allows the touch screen to be mounted into a 19 in. rack. When installed, the touch screen occupies three rack spaces.¹

The TSW-570 is also compatible with Wall-Smart® flush wall mount products via a partnership with Crestron. For more information on supported Wall-Smart hardware, click [here](#).

TSW-570

5 in. Wall Mount Touch Screen

Specifications

Touch Screen Display

Display Type	TFT active matrix color LCD
Size	5 in. (127 mm) diagonal
Aspect Ratio	16:9 HD 720
Resolution	1280 x 720 pixels
Brightness	400 nits (cd/m ²)
Contrast	800:1
Color Depth	24 bit, 16.7M colors
Illumination	Edgelit LED with auto brightness control
Viewing Angle	±80° horizontal, ±80° vertical
Touch Screen	Projected capacitive, 5-point multitouch capable

Buttons

Virtual Buttons	(5) Virtual buttons in collapsible universal tool bar, per-button show/hide, preconfigured with icons for Power, Home, Lights, Up, and Down, optional custom programming via control system for additional functions
Reset	(1) Pin hole on rear panel for hardware reset

Graphics Engine

Crestron HTML5 and Smart Graphics® software technology, multilanguage web browser³, multilanguage onscreen keyboard, screensaver, single scalable streaming video window, native room scheduling application², native Crestron Home™ OS app, setup and diagnostics via web browser, cloud, or onscreen UI

Room Scheduling Support

Crestron Scheduling App	Crestron Fusion® software, Microsoft Exchange Server® and Office 365® software, Google Calendar™ calendaring app and G Suite™ software, CollegeNET® 25Live® software, and Ad Astra™ software (IBM® Notes® software is also supported through Crestron Fusion on-premises server only) ²
--------------------------------	--

Languages

Smart Graphics	Arabic, Chinese (Simplified), Chinese (Traditional), Czech, Danish, Dutch, English (UK), English (US), Finnish, French, German, Greek, Hebrew, Hungarian, Italian, Japanese, Korean, Norwegian, Polish, Portuguese, Portuguese (Brazilian), Romanian, Russian, Slovak, Spanish, Swedish, Thai
Onscreen Keyboard	Arabic, Chinese (Simplified), Croatian, Czech, Danish, Dutch, English (UK), English (US), Finnish, French (Canada), French (Switzerland), German, Hebrew, Hungarian, Italian, Japanese, Norwegian Bokmal, Polish, Portuguese, Russian, Serbian, Spanish, Swedish, Turkish
Web Browser³	Arabic, Bulgarian, Catalan, Chinese, Croatian, Czech, Danish, Dutch, English, Filipino, Finnish, French, German, Greek, Hebrew, Hindi, Hungarian, Indonesian, Italian, Japanese, Korean, Latvian, Lithuanian, Norwegian Bokmal, Pashto, Persian, Polish, Portuguese, Romanian, Romansh, Russian, Serbian, Slovak, Slovenian, Spanish, Swedish, Thai, Turkish, Ukrainian, Vietnamese
Room Scheduling²	Chinese (Simplified), Chinese (Traditional), Danish, Dutch (Netherlands), English (US), English (UK), French, German, Hebrew, Italian, Japanese, Korean, Norwegian, Portuguese (Brazil), Portuguese (Portugal), Russian, Spanish, Swedish
Memory	
RAM	2 GB LPDDR3
Storage	Firmware/Application: 16 GB eMMC pSLC
Maximum Project Size	600 MB
Wired Communications	
Ethernet	100 Mbps, auto switching, auto negotiating, auto discovery, full/half duplex, TCP/IP, UDP/IP, CIP, DHCP, SSL, TLS, SSH, SFTP (SSH File Transfer Protocol), IEEE 802.1X, SNMP, IPv4 or IPv6, Active Directory® service authentication, HTTPS web browser setup, XiO Cloud® client, IEEE 802.3at compliant
USB	USB 2.0 host for room scheduling accessories

TSW-570

5 in. Wall Mount Touch Screen

Streaming Decoder

Video Formats	H.265, H.264 (MPEG-4 part 10 AVC, MJPEG)
Audio Formats	AAC Stereo
Bitrates	Up to 25 Mbps (20 Mbps maximum recommended)
Input Resolutions	Up to 1920x1080@30fps
Protocol	RTSP

Connectors

LAN PoE	(1) 8-pin RJ45 connector, female, with 2 LED indicators; 100BASE-TX Ethernet port; PoE+ PD port; Green and yellow LEDs indicate Ethernet port status
USB	(2) USB Type A connectors, female; USB 2.0 host ports; For optional room scheduling accessories ³

Power

PoE (Power over Ethernet)	IEEE 802.3at Type 2 compliant PoE+ PD (Powered Device); Requests 15 W from an 802.3at Type 2 PSE with LLDP advanced power management; Requests 30 W (PoE+ Class 4) from an 802.3at Type 2 PSE without LLDP; Requests 15.4 W (PoE Class 0) from an 802.3af (or 802.3at Type 1) PSE
----------------------------------	--

Environmental

Temperature	32 to 104 °F (0 to 40 °C)
Humidity	10% to 95% RH (noncondensing)
Heat Dissipation	44 BTU/hr

Construction

Housing	Plastic, smooth black or white finish, edge-to-edge glass with black or white surround
Mounting	Surface mount over a 2 in. H x 3-3/4 in. W (51 mm H x 96 mm W) cutout; 2-13/16 in. (72 mm) minimum mounting depth; 1-1/4 in. (32 mm) maximum mounting surface thickness; Pre/postconstruction mounting bracket assembly included; Back box and rack mount options sold separately

Dimensions

Height	2.84 in. (72 mm)
Width	5.14 in. (131 mm)
Depth	1.97 in. (50 mm)

Dimensions do not include mounting bracket or add-on accessories

Weight

8.82 oz (250 g)

Compliance

Regulatory Model:

IC, CE, FCC Part 15 Class B digital device

Models

TSW-570-B-S

5 in. Wall Mount Touch Screen, Black Smooth

TSW-570-W-S

5 in. Wall Mount Touch Screen, White Smooth

Included Accessories

TSW-UMB-70

Universal Mounting Bracket for TSW-70 Series

TSW-UMB-70-PMK

Preconstruction Mounting Kit for TSW-UMB-70

Available Accessories

For supported accessories, visit the appropriate TSW-570 product page at www.crestron.com.

Notes:

1. Item(s) sold separately. Refer to each product's spec sheet for complete information.
2. Web browsing, weather information, and certain other functions require an Internet connection.
3. Room scheduling mode requires the TSW-570 to be designated exclusively for room scheduling use, which precludes use of certain features and functions described in this spec sheet. For design assistance, contact the Crestron True Blue support team at www.crestron.com/support.
4. The TSW-UMB-70 is also compatible with older TSW-UMB-PMK series preconstruction mounting kits and TSW-BBI series back boxes, allowing the TSW-570 to be installed in place of a previous generation touch screen.

TSW-570

5 in. Wall Mount Touch Screen

This product may be purchased from select authorized Crestron dealers and distributors. To find a dealer or distributor, please contact the Crestron sales representative for your area. A list of sales representatives is available online at www.crestron.com/How-To-Buy/Find-a-Representative or by calling 855-263-8754.

This product is covered under the Crestron standard limited warranty. Refer to www.crestron.com/warranty for full details.

The specific patents that cover Crestron products are listed online at patents.crestron.com.

Certain Crestron products contain open source software. For specific information, please visit www.crestron.com/opensource.

Crestron, the Crestron logo, Cresnet, Crestron Fusion, Crestron Home, DigitalMedia, and Smart Graphics, and XiO Cloud are either trademarks or registered trademarks of Crestron Electronics, Inc. in the United States and/or other countries. Ad Astra is either a trademark or a registered trademark of Ad Astra Information Systems, LLC in the United States and/or other countries. CollegeNET and 25Live are either trademarks or registered trademarks of CollegeNET, Inc. in the United States and/or other countries. G Suite and Google Calendar are either trademarks or registered trademarks of Google, Inc. in the United States and/or other countries. IBM and Notes are either trademarks or registered trademarks of International Business Machines Corporation in the United States and/or other countries. Microsoft, Active Directory, Azure, Microsoft Exchange Server, Office 365, and Outlook are either trademarks or registered trademarks of Microsoft Corporation in the United States and/or other countries. UL is either a trademark or a registered trademark of Underwriters Laboratories, Inc. in the United States and/or other countries. Wall-Smart is either a trademark or registered trademark of Wall-Smart Ltd. in the United States and/or other countries. Other trademarks, registered trademarks, and trade names may be used in this document to refer to either the entities claiming the marks and names or their products. Crestron disclaims any proprietary interest in the marks and names of others. Crestron is not responsible for errors in typography or photography.

Specifications are subject to change without notice.

©2021 Crestron Electronics, Inc.

Rev 11/23/21

TSW-570

5 in. Wall Mount Touch Screen

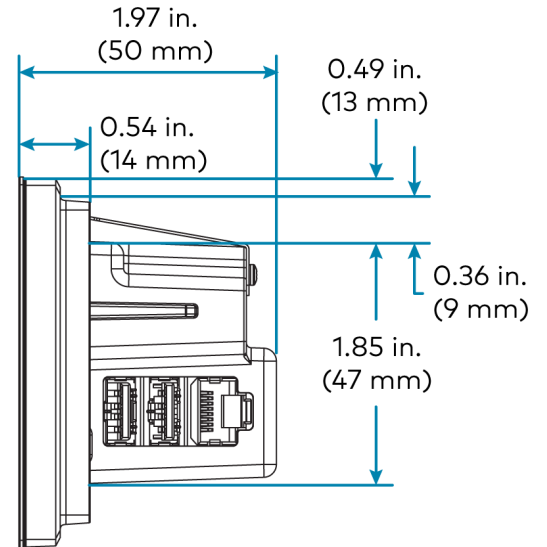
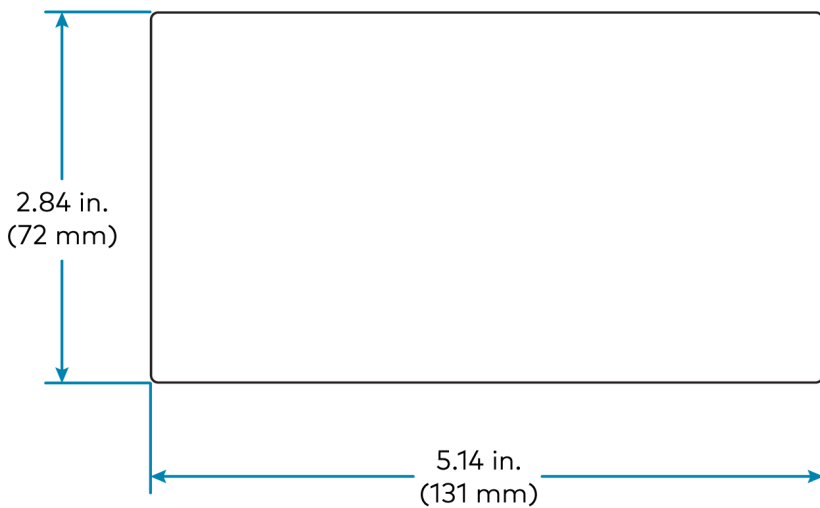
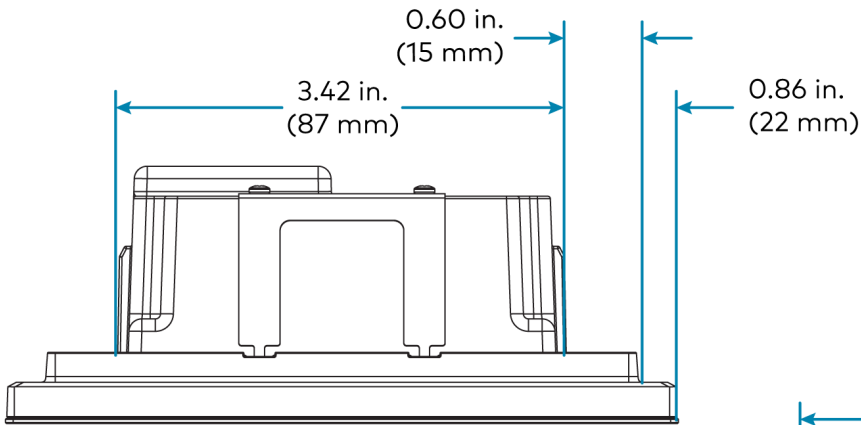
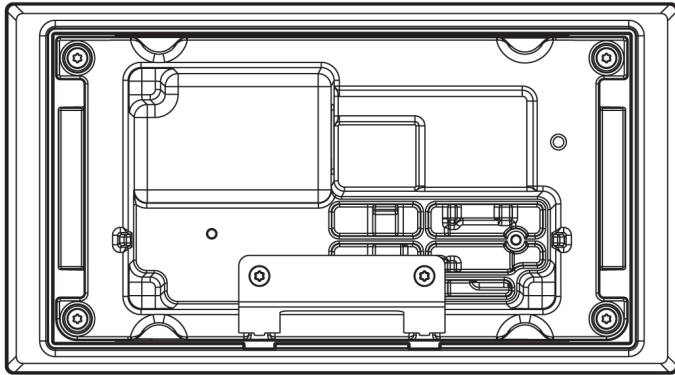

TSW-570

5 in. Wall Mount Touch Screen

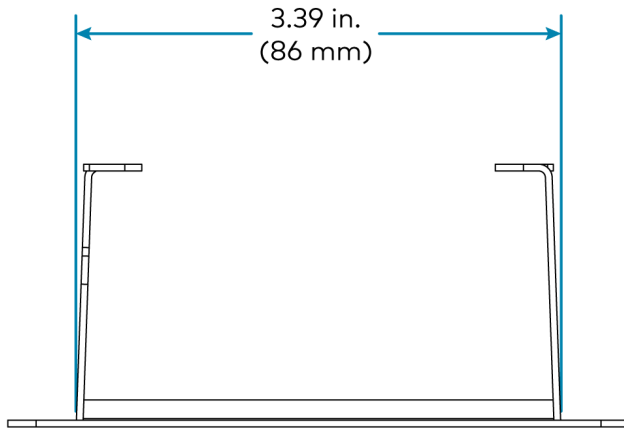

TSW-570 Mounting Bracket

