

Specifications

TouchLink Adapter Mounts

General

Mounting Drywall or backbox
 TLA 2
 Enclosure dimensions..... 6.39" H x 8.46" W x 1.52" D (162 mm H x 215 mm W x 38 mm D)

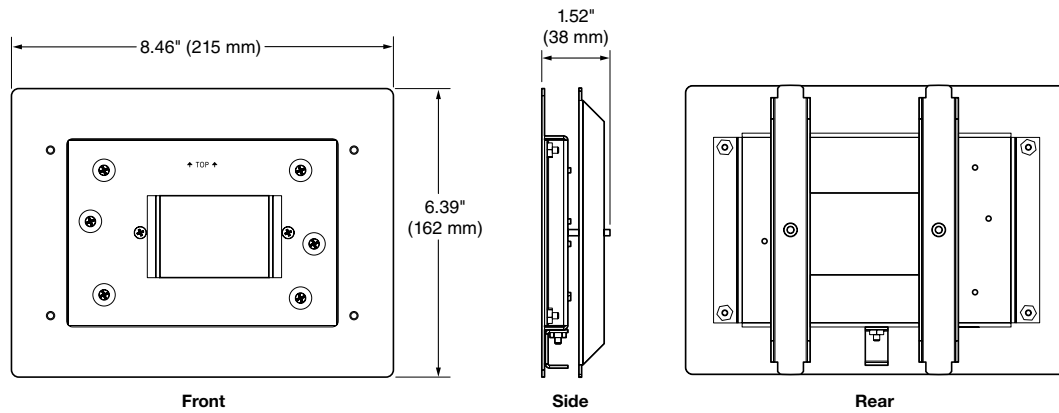

TLA 2

TLA 3
 Enclosure dimensions..... 7.95" H x 11.12" W x 1.52" D (202 mm H x 282 mm W x 38 mm D)

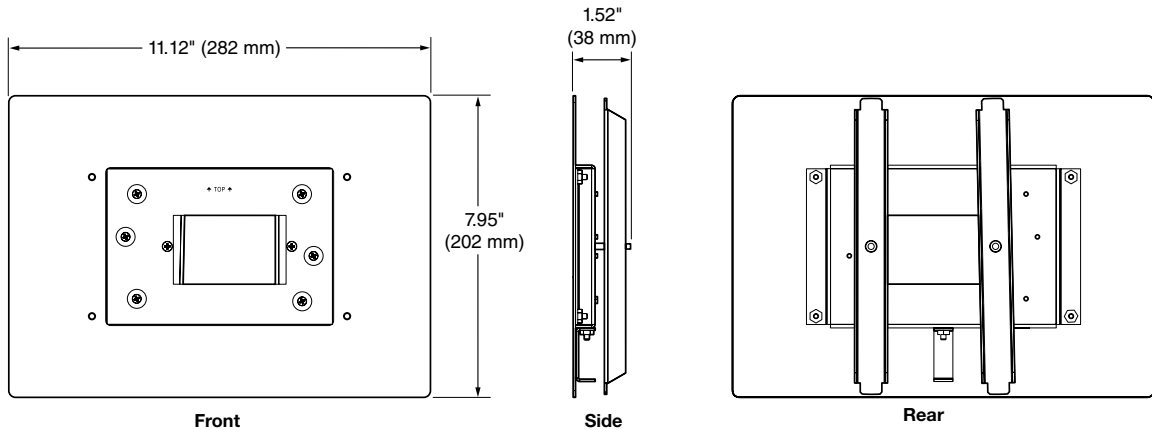

TLA 3

Product weight
 TLA 2 1.50 lbs (0.68 kg)
 TLA 3 2.50 lbs (1.13 kg)
 Enclosure material..... Metal
 Regulatory compliance..... CE, RoHS, WEEE
 Warranty 3 years parts and labor

NOTES:

- Specifications are subject to change without notice.
- Shipping weights and dimensions are available at www.extron.com.